

SECTION A-A

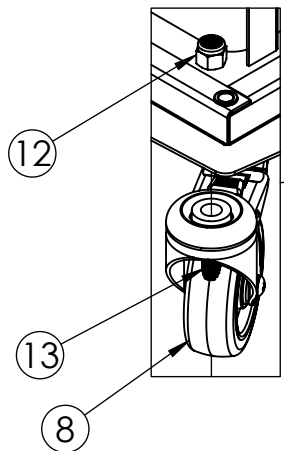

BOM Table			
NO	Part Number	Description	QTY.
1	Par--20039816	Twin Top Hole Cover	1
2	Par--20006426	AVR Rack Rail	8
3	Ass--20026493	Twin Avr Cabinet Back Panel With Multi Vent Doors	1
4	Ass--20026380	Twin Cabinet Crocodile Column Mount	1
5	Ass--20022730	Twin Avr Cabinet Front Post	1
6	Ass--20022727	Twin Avr Cabinet Rear Post	1
7	Ass--20003649	AVR Door	2
8	Ass--20001782	BC10 Stanadard Brake Castor	4
9	ASS--20030159	Avrt5 Twin Media Cabinet 442Mm 17.4 Inch Usable Depth 14U Rack Top	1
10	ASS--20030157	Avrt5 Twin Media Cabinet 442Mm 17.4 Inch Usable Depth 14U Rack Base	1
11	ASS--20030155	Avrt5 Twin Media Cabinet 442Mm 17.4 Inch Usable Depth 14U Rack Right Side	2
12	NN-MET-12-HT-CZN	Nylon Lock Nut M12 (High Tensile Bright Zinc Plated Clear Passivated)	4
13	HMS-MET-12X35-HT-BO	Hex Machine Screw M12 X 35 (High Tensile Black Oxide)	4

Description		Avrt5 Twin Media Cabinet 442Mm 17.4 Inch Usable Depth 14u Rack	
UNLESS OTHERWISE SPECIFIED: DIMENSIONS ARE IN MILLIMETERS	Created By	System Administrator	DRW - REV REV - A-002
	Created By	System Administrator	
SURFACE FINISH: Powder Coated	Material:		See Below - Special Notes
	Gauge:		
Created By System Administrator Unicol Engineering Green Road Oxford OX3 8EU	Part Number & Part Revision		ASS--20030153 REV - A-002

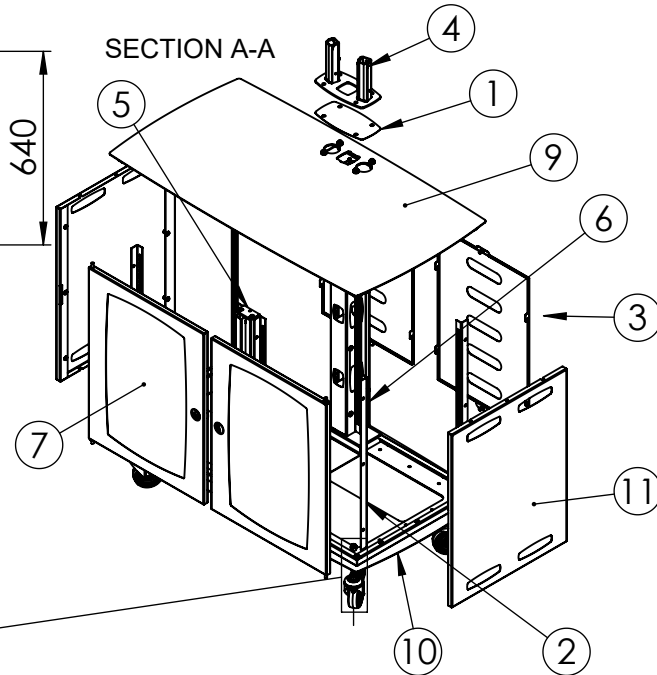
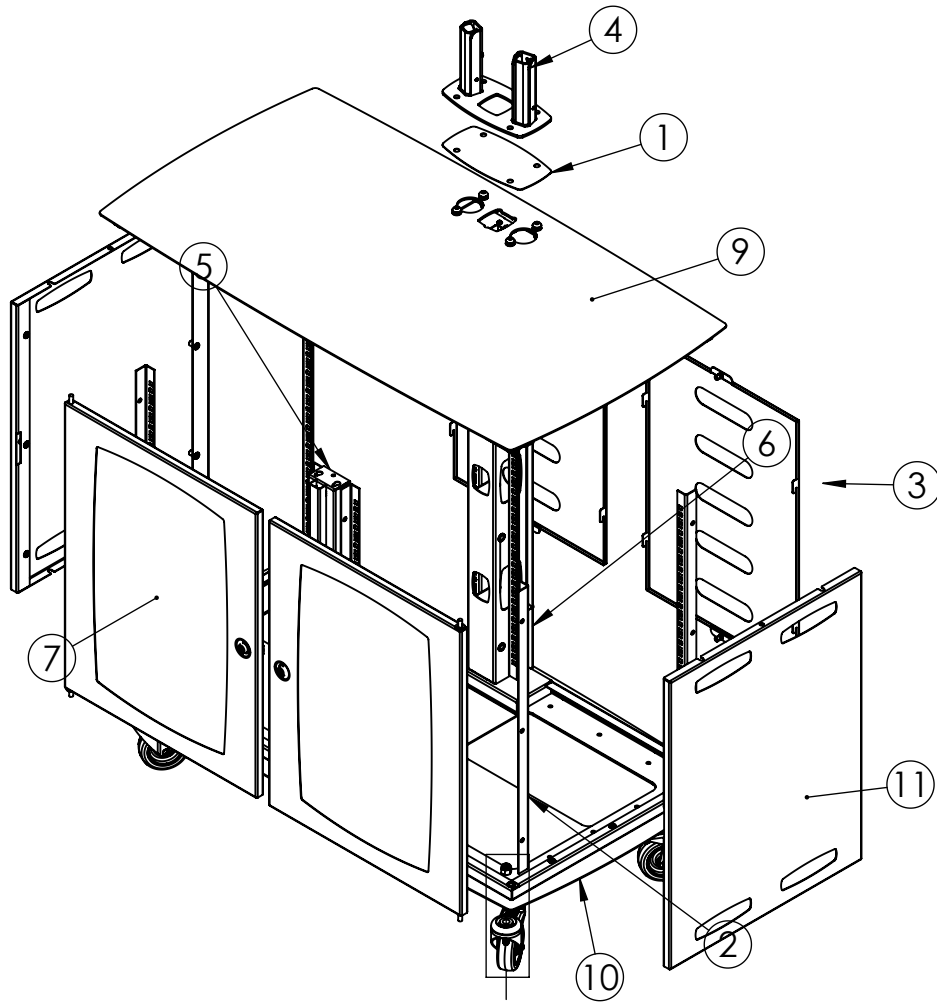

BOM Table			
NO	Part Number	Description	QTY.
6	BH-MET-6X16-HT-BO	Button Head Screw M6 X 16 (High Tensile Black Oxide)	24
9	NN-MET-12-HT-CZN	Nylon Lock Nut M12 (High Tensile Bright Zinc Plated Clear Passivated)	4
10	HMS-MET-12X35-HT-BO	Hex Machine Screw M12 X 35 (High Tensile Black Oxide)	4
43	BC10	10cm Braked Castor - Single	4

Description		Avrt5 Twin Media Cabinet 442Mm 17.4 Inch Usable Depth 14u Rack	
UNLESS OTHERWISE SPECIFIED: DIMENSIONS ARE IN MILLIMETERS		Modified Date: 10 December 2021 Created Date: 19 July 2011 Bend Tool:	DRW - REV REV - A-002
SURFACE FINISH: Powder Coated		Material:	
Created By System Administrator Unicol Engineering Green Road Oxford OX3 8EU		Gauge:	Part Number & Part Revision ASS--20030153 REV - A-002

WEIGHT: 91.86 Kg

SCALE:1:15 DO NOT SCALE DRAWING SHEET 2 OF 2