

from 73 mm to 310 mm open

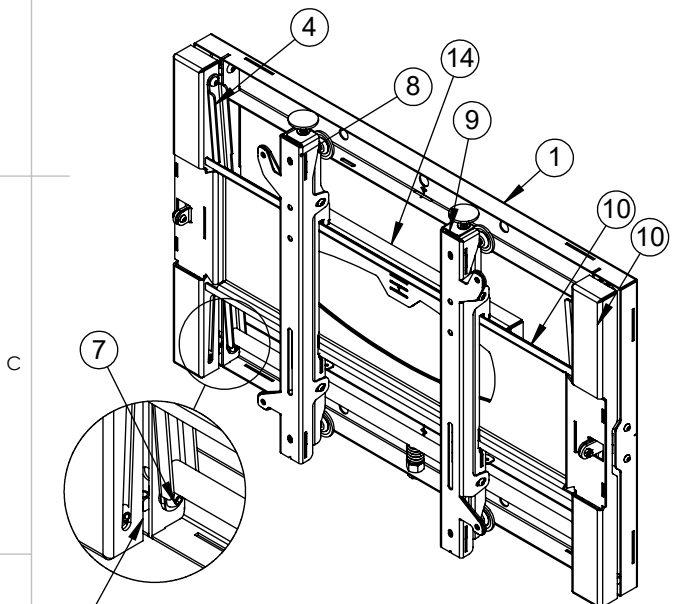

BOM Table

NO	Part Number	Description	QTY.
1	ASS--20054343	Vwp1 - Wall Plate H-D	1
2	HMS-MET-12X35-HT-BO	Hex Machine Screw M12 X 35 ( High Tensile Black Oxide )	1
3	Ass--20016126	Spring Ass For Pop Out Video Wall	1
4	Ass--20015769	Vwp1 - Bottom Scissor Frame	1
5	Par--20025527	Scissor Arm	2
6	FW-MET-8-HT-CZN	Flat Washer M8 ( High Tensile Bright Zinc Plated Clear Passivated )	20
7	BH-MET-8X20-HT-BO	Button Head Screw M8 X 20 ( High Tensile Black Oxide )	8
8	ASS--20054305	Video Wall Arm 200 - 300 - 400 Extension H-D	1
9	ASS--20054306	Video Wall Arm 200 -300 -400 Extension Right H-D	1
10	ASS--20054344	Vwp1 Front Slider Arms Support H-D	1
11	Par--20017909	Nylon Bush 5.25 X 10 X 10	2
12	BN-MET-8-HT-CZN	Binx Nut M8 ( High Tensile Bright Zinc Plated Clear Passivated )	10
13	BH-MET-8X20-HT-CZN	Button Head Screw M8 X 20 ( High Tensile Bright Zinc Plated Clear Passivated )	2
14	PAR--2055934	Vwp1 - back stress plate	1

Description Vwp1 - Video Wall Unit 300 to 600 Vesa H-D 80 Kg

UNLESS OTHERWISE SPECIFIED:  
DIMENSIONS ARE IN MILLIMETERS

SURFACE FINISH: Powder Coated

Created By Dennis Neale

Unicol Engineering  
Green Road  
Oxford OX3 8EU

Saved Date: 04 February 2022

Created Date: 02 September 2021

Bend Tool:

Material:

Gauge:

DRW - REV

REV -  
A-002

See Below - Special Notes

Part Number & Part Revision

ASS--20054304 REV - A-002

WEIGHT: 16.28

Kg

SCALE:1:10

DO NOT SCALE DRAWING

SHEET 1 OF 2